



MC34129 MC33129

High Performance Current Mode Controllers

The MC34129/MC33129 are high performance current mode switching regulators specifically designed for use in low power digital telephone applications. These integrated circuits feature a unique internal fault timer that provides automatic restart for overload recovery. For enhanced system efficiency, a start/run comparator is included to implement bootstrapped operation of V_{CC} . Other functions contained are a temperature compensated reference, reference amplifier, fully accessible error amplifier, sawtooth oscillator with sync input, pulse width modulator comparator, and a high current totem pole driver ideally suited for driving a power MOSFET.

Also included are protective features consisting of soft-start, undervoltage lockout, cycle-by-cycle current limiting, adjustable deadtime, and a latch for single pulse metering.

Although these devices are primarily intended for use in digital telephone systems, they can be used cost effectively in many other applications.

- Current Mode Operation to 300 kHz
- Automatic Feed Forward Compensation
- Latching PWM for Cycle-by-Cycle Current Limiting
- Continuous Retry after Fault Timeout
- Soft-Start with Maximum Peak Switch Current Clamp
- Internally Trimmed 2% Bandgap Reference
- High Current Totem Pole Driver
- Input Undervoltage Lockout
- Low Startup and Operating Current
- Direct Interface with Motorola SENSEFET Products

HIGH PERFORMANCE CURRENT MODE CONTROLLERS

SEMICONDUCTOR TECHNICAL DATA

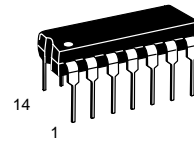

P SUFFIX
PLASTIC PACKAGE
CASE 646

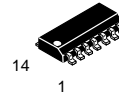

D SUFFIX
PLASTIC PACKAGE
CASE 751A
(SO-14)

PIN CONNECTIONS

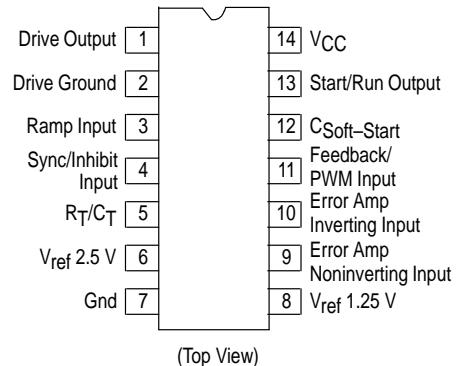

Simplified Block Diagram

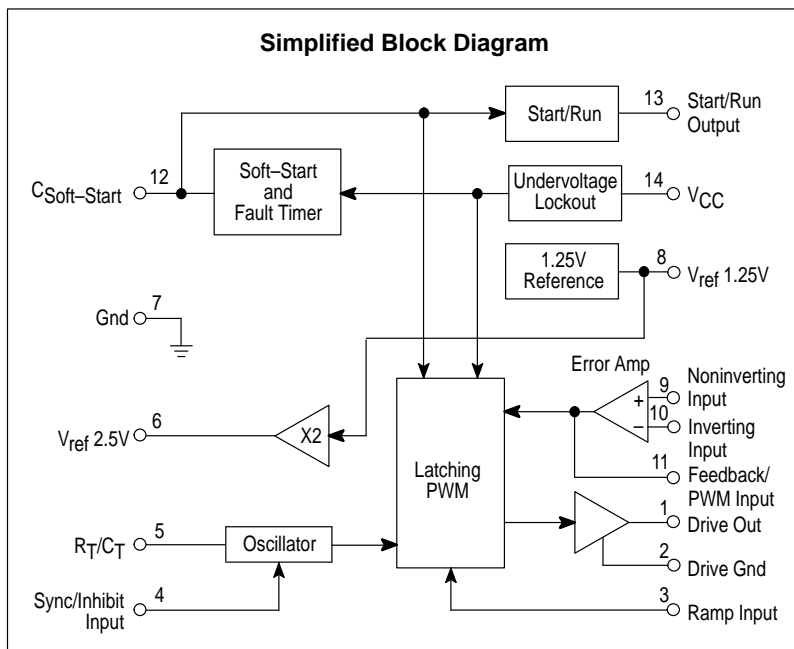

ORDERING INFORMATION

Device	Operating Temperature Range	Package
MC34129D	$T_A = 0^\circ \text{ to } +70^\circ\text{C}$	SO-14
MC34129P		Plastic DIP
MC33129D	$T_A = -40^\circ \text{ to } +85^\circ\text{C}$	SO-14
MC33129P		Plastic DIP

MAXIMUM RATINGS

Rating	Symbol	Value	Unit
V _{CC} Zener Current	I _{Z(VCC)}	50	mA
Start/Run Output Zener Current	I _{Z(Start/Run)}	50	mA
Analog Inputs (Pins 3, 5, 9, 10, 11, 12)	–	–0.3 to 5.5	V
Sync Input Voltage	V _{sync}	–0.3 to V _{CC}	V
Drive Output Current, Source or Sink	I _{DRV}	1.0	A
Current, Reference Outputs (Pins 6, 8)	I _{ref}	20	mA
Power Dissipation and Thermal Characteristics D Suffix, Plastic Package Case 751A Maximum Power Dissipation @ T _A = 70°C Thermal Resistance, Junction-to-Air	P _D R _{θJA}	552 145	mW °C/W
P Suffix, Plastic Package Case 646 Maximum Power Dissipation @ T _A = 70°C Thermal Resistance, Junction-to-Air	P _D R _{θJA}	800 100	mW °C/W
Operating Junction Temperature	T _J	+150	°C
Operating Ambient Temperature MC34129 MC33129	T _A	0 to +70 –40 to +85	°C
Storage Temperature Range	T _{stg}	–65 to +150	°C

ELECTRICAL CHARACTERISTICS (V_{CC} = 10 V, T_A = 25°C [Note 1], unless otherwise noted.)

Characteristics	Symbol	Min	Typ	Max	Unit
-----------------	--------	-----	-----	-----	------

REFERENCE SECTIONS

Reference Output Voltage, T _A = 25°C 1.25 V Ref., I _L = 0 mA 2.50 V Ref., I _L = 1.0 mA	V _{ref}	1.225 2.375	1.250 2.500	1.275 2.625	V
Reference Output Voltage, T _A = T _{low} to T _{high} 1.25 V Ref., I _L = 0 mA 2.50 V Ref., I _L = 1.0 mA	V _{ref}	1.200 2.250	– –	1.300 2.750	V
Line Regulation (V _{CC} = 4.0 V to 12 V) 1.25 V Ref., I _L = 0 mA 2.50 V Ref., I _L = 1.0 mA	Reg _{line}	– –	2.0 10	12 50	mV
Load Regulation 1.25 V Ref., I _L = –10 μA to +500 μA 2.50 V Ref., I _L = –0.1 mA to +1.0 mA	Reg _{load}	– –	1.0 3.0	12 25	mV

ERROR AMPLIFIER

Input Offset Voltage (V _{in} = 1.25 V) T _A = 25°C T _A = T _{low} to T _{high}	V _{IO}	– –	1.5 –	– 10	mV
Input Offset Current (V _{in} = 1.25 V)	I _{IO}	–	10	–	nA
Input Bias Current (V _{in} = 1.25 V) T _A = 25°C T _A = T _{low} to T _{high}	I _{IB}	– –	25 –	– 200	nA
Input Common Mode Voltage Range	V _{ICR}	–	0.5 to 5.5	–	V
Open Loop Voltage Gain (V _O = 1.25 V)	A _{VOL}	65	87	–	dB
Gain Bandwidth Product (V _O = 1.25 V, f = 100 kHz)	GBW	500	750	–	kHz
Power Supply Rejection Ratio (V _{CC} = 5.0 V to 10 V)	PSRR	65	85	–	dB
Output Source Current (V _O = 1.5 V)	I _{Source}	40	80	–	μA
Output Voltage Swing High State (I _{Source} = 0 μA) Low State (I _{Sink} = 500 μA)	V _{OH} V _{OL}	1.75 –	1.96 0.1	2.25 0.15	V

NOTE: 1. T_{low} = 0°C for MC34129
–40°C for MC33129

T_{high} = +70°C for MC34129
+85°C for MC33129

ELECTRICAL CHARACTERISTICS ($V_{CC} = 10\text{ V}$, $T_A = 25^\circ\text{C}$ [Note 1], unless otherwise noted.)

Characteristics	Symbol	Min	Typ	Max	Unit
PWM COMPARATOR					
Input Offset Voltage ($V_{in} = 1.25\text{ V}$)	V_{IO}	150	275	400	mV
Input Bias Current	I_{IB}	–	–120	–250	μA
Propagation Delay, Ramp Input to Drive Output	$t_{PLH(IN/DRV)}$	–	250	–	ns
SOFT-START					
Capacitor Charge Current (Pin 12 = 0 V)	I_{chg}	0.75	1.2	1.50	μA
Buffer Input Offset Voltage ($V_{in} = 1.25\text{ V}$)	V_{IO}	–	15	40	mV
Buffer Output Voltage ($I_{Sink} = 100\ \mu\text{A}$)	V_{OL}	–	0.15	0.225	V
FAULT TIMER					
Restart Delay Time	t_{DLY}	200	400	600	μs
START/RUN COMPARATOR					
Threshold Voltage (Pin 12)	V_{th}	–	2.0	–	V
Threshold Hysteresis Voltage (Pin 12)	V_H	–	350	–	mV
Output Voltage ($I_{Sink} = 500\ \mu\text{A}$)	V_{OL}	9.0	10	10.3	V
Output Off-State Leakage Current ($V_{OH} = 15\text{ V}$)	$I_{S/R(leak)}$	–	0.4	2.0	μA
Output Zener Voltage ($I_Z = 10\text{ mA}$)	V_Z	–	($V_{CC} + 7.6$)	–	V
OSCILLATOR					
Frequency ($R_T = 25.5\text{ k}\Omega$, $C_T = 390\text{ pF}$)	f_{OSC}	80	100	120	kHz
Capacitor C_T Discharge Current (Pin 5 = 1.2 V)	I_{dischg}	240	350	460	μA
Sync Input Current High State ($V_{in} = 2.0\text{ V}$) Low State ($V_{in} = 0.8\text{ V}$)	I_{IH} I_{IL}	– –	40 15	125 35	μA
Sync Input Resistance	R_{in}	12.5	32	50	$\text{k}\Omega$
DRIVE OUTPUT					
Output Voltage High State ($I_{Source} = 200\text{ mA}$) Low State ($I_{Source} = 200\text{ mA}$)	V_{OH} V_{OL}	8.3 –	8.9 1.4	– 1.8	V
Low State Holding Current	I_H	–	225	–	μA
Output Voltage Rise Time ($C_L = 500\text{ pF}$)	t_r	–	390	–	ns
Output Voltage Fall Time ($C_L = 500\text{ pF}$)	t_f	–	30	–	ns
Output Pull-Down Resistance	R_{PD}	100	225	350	$\text{k}\Omega$
UNDERVOLTAGE LOCKOUT					
Startup Threshold	V_{th}	3.0	3.6	4.2	V
Hysteresis	V_H	5.0	10	15	%
TOTAL DEVICE					
Power Supply Current $R_T = 25.5\text{ k}\Omega$, $C_T = 390\text{ pF}$, $C_L = 500\text{ pF}$	I_{CC}	1.0	2.5	4.0	mA
Power Supply Zener Voltage ($I_Z = 10\text{ mA}$)	V_Z	12	14.3	–	V

NOTE: 1. $T_{low} = 0^\circ\text{C}$ for MC34129
–40°C for MC33129

$T_{high} = +70^\circ\text{C}$ for MC34129
+85°C for MC33129

Figure 1. Timing Resistor versus Oscillator Frequency

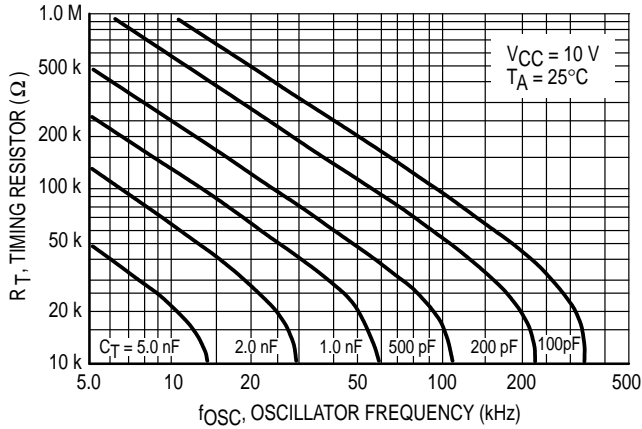

Figure 2. Output Deadtime versus Oscillator Frequency

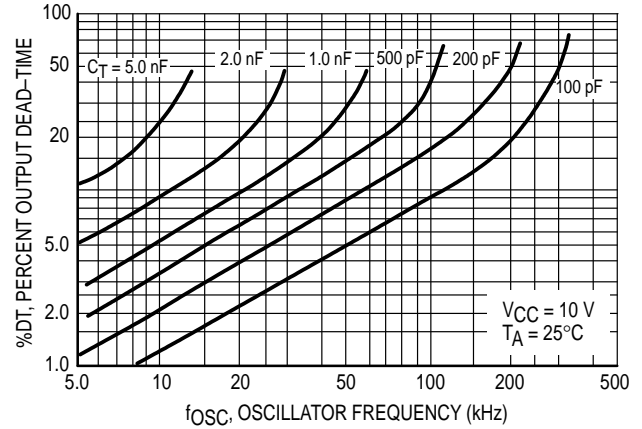

Figure 3. Oscillator Frequency Change versus Temperature

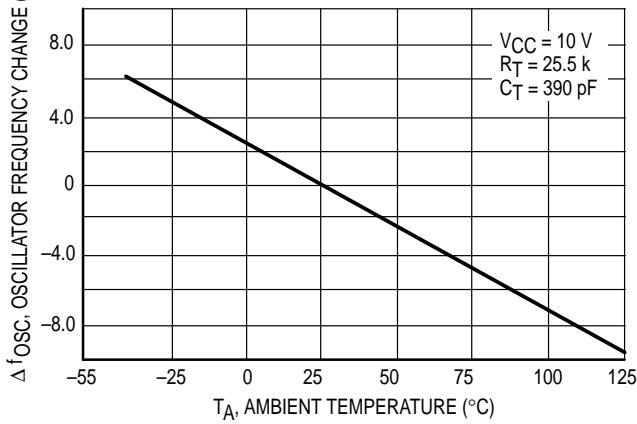

Figure 4. Error Amp Open Loop Gain and Phase versus Frequency

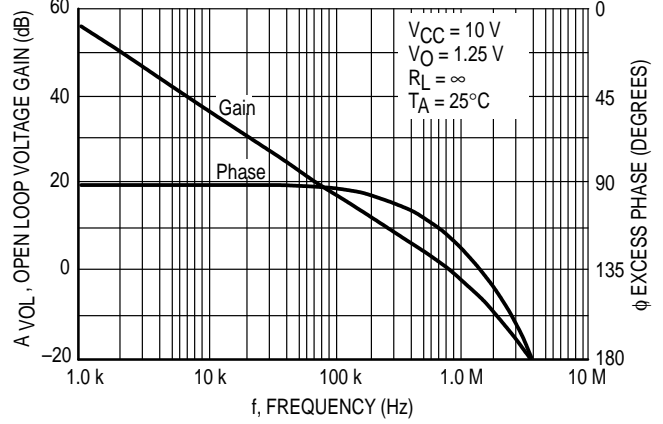

Figure 5. Error Amp Small-Signal Transient Response

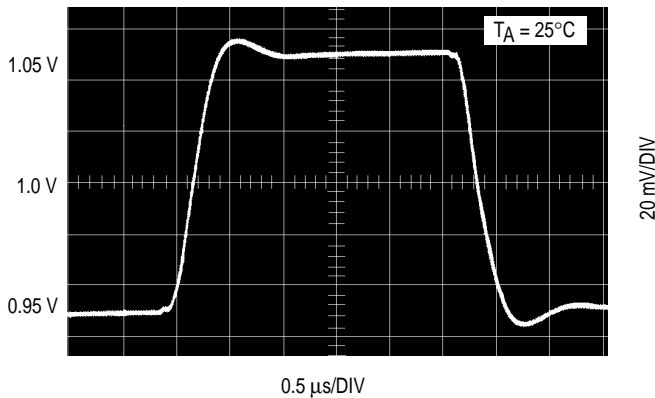

Figure 6. Error Amp Large-Signal Transient Response

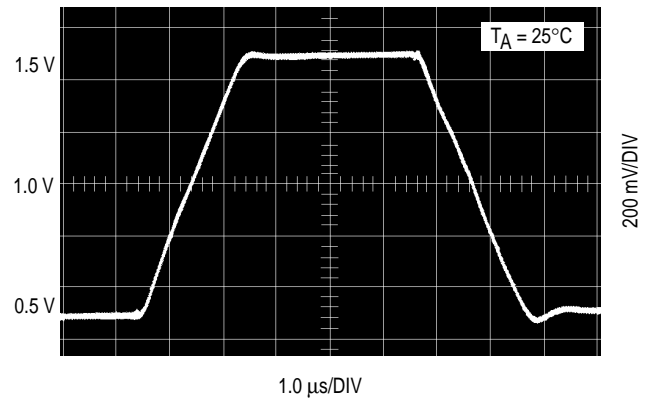

Figure 7. Error Amp Open Loop DC Gain versus Load Resistance

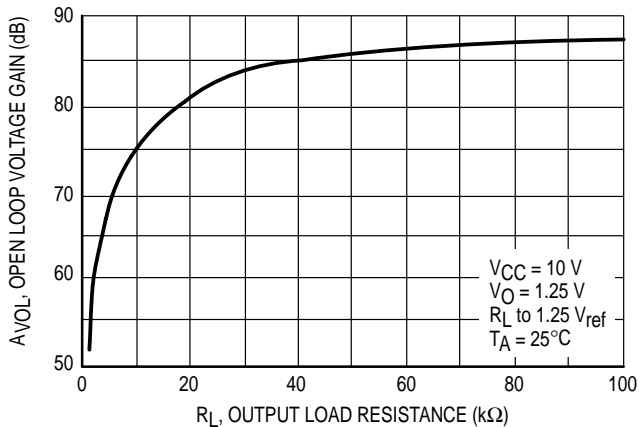

Figure 8. Error Amp Output Saturation versus Sink Current

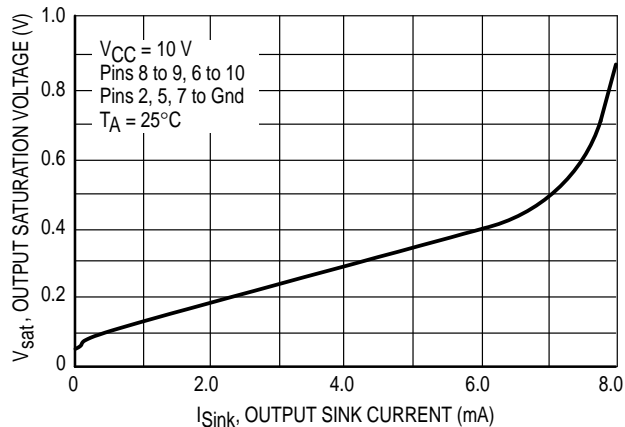

Figure 9. Soft-Start Buffer Output Saturation versus Sink Current

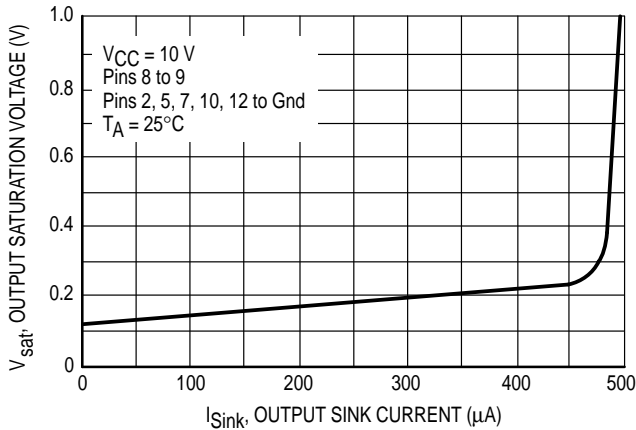

Figure 10. Reference Output Voltage versus Supply Voltage

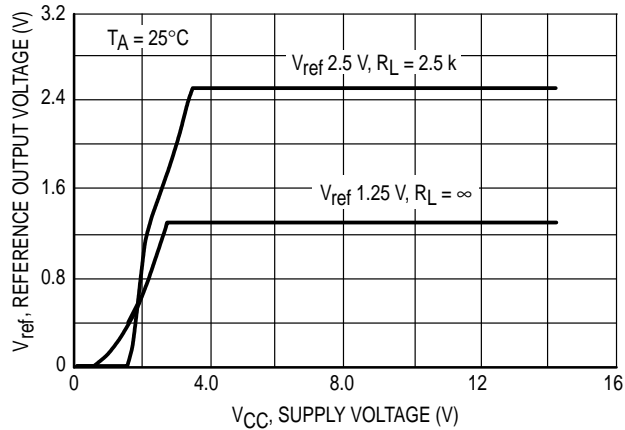

Figure 11. 1.25 V Reference Output Voltage Change versus Source Current

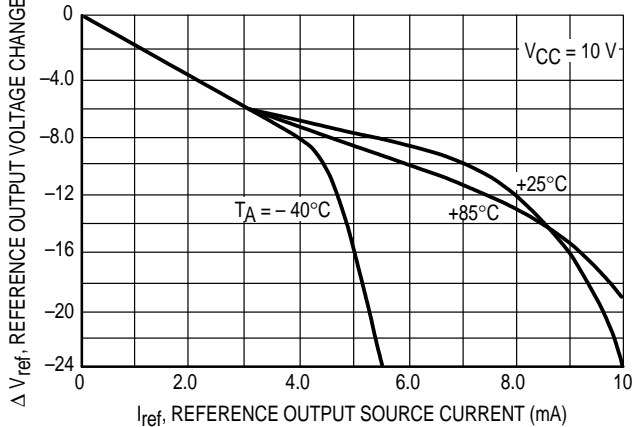
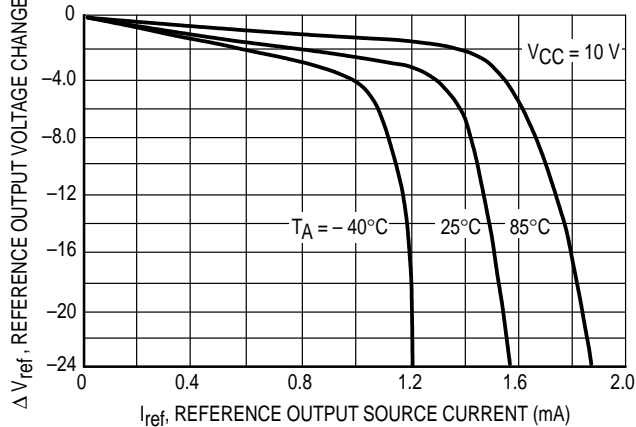

Figure 12. 2.5 V Reference Output Voltage Change versus Source Current



PIN FUNCTION DESCRIPTION

Pin	Function	Description
1	Drive Output	This output directly drives the gate of a power MOSFET. Peak currents up to 1.0 A are sourced and sunk by this pin.
2	Drive Ground	This pin is a separate power ground return that is connected back to the power source. It is used to reduce the effects of switching transient noise on the control circuitry.
3	Ramp Input	A voltage proportional to the inductor current is connected to this input. The PWM uses this information to terminate output switch conduction.
4	Sync/Inhibit Input	A rectangular waveform applied to this input will synchronize the Oscillator and limit the maximum Drive Output duty cycle. A dc voltage within the range of 2.0 V to V_{CC} will inhibit the controller.
5	R_T/C_T	The free-running Oscillator frequency and maximum Drive Output duty cycle are programmed by connecting resistor R_T to V_{ref} 2.5 V and capacitor C_T to Ground. Operation to 300 kHz is possible.
6	V_{ref} 2.50 V	This output is derived from V_{ref} 1.25 V. It provides charging current for capacitor C_T through resistor R_T .
7	Ground	This pin is the control circuitry ground return and is connected back to the source ground.
8	V_{ref} 1.25 V	This output furnishes a voltage reference for the Error Amplifier noninverting input.
9	Error Amp Noninverting Input	This is the noninverting input of the Error Amplifier. It is normally connected to the 1.25 V reference.
10	Error Amp Inverting Input	This is the inverting input of the Error Amplifier. It is normally connected to the switching power supply output through a resistor divider.
11	Feedback/PWM Input	This pin is available for loop compensation. It is connected to the Error Amplifier and Soft-Start Buffer outputs, and the Pulse Width Modulator input.
12	$C_{Soft-Start}$	A capacitor $C_{Soft-Start}$ is connected from this pin to Ground for a controlled ramp-up of peak inductor current during startup.
13	Start/Run Output	This output controls the state of an external bootstrap transistor. During the start mode, operating bias is supplied by the transistor from V_{in} . In the run mode, the transistor is switched off and bias is supplied by an auxiliary power transformer winding.
14	V_{CC}	This pin is the positive supply of the control IC. The controller is functional over a minimum V_{CC} range of 4.2 V to 12 V.

OPERATING DESCRIPTION

The MC34129 series are high performance current mode switching regulator controllers specifically designed for use in low power telecommunication applications. Implementation will allow remote digital telephones and terminals to shed their power cords and derive operating power directly from the twisted pair used for data transmission. Although these devices are primarily intended for use in digital telephone systems, they can be used cost effectively in a wide range of converter applications. A representative block diagram is shown in Figure 18.

Oscillator

The oscillator frequency is programmed by the values selected for the timing components R_T and C_T . Capacitor C_T is charged from the 2.5 V reference through resistor R_T to approximately 1.25 V and discharged by an internal current sink to ground. During the discharge of C_T , the oscillator generates an internal blanking pulse that holds the lower input of the NOR gate high. This causes the Drive Output to be in a low state, thus producing a controlled amount of output deadtime. Figure 1 shows Oscillator Frequency versus R_T and Figure 2 Output Deadtime versus Frequency, both for given values of C_T . Note that many values of R_T and C_T will give the same oscillator frequency but only one combination will yield a specific output deadtime at a give frequency. In many noise sensitive applications it may be desirable to frequency-lock one or more switching regulators to an external system clock. This can be accomplished by applying the clock signal to the Synch/Inhibit Input. For reliable locking, the free-running oscillator frequency should be about 10% less than the clock frequency. Referring to the timing diagram shown Figure 19, the rising edge of the clock signal applied to the Sync/Inhibit Input, terminates charging of C_T and Drive Output conduction. By tailoring the clock waveform, accurate duty cycle clamping of the Drive Output can be achieved. A circuit method is shown in Figure 20. The Sync/Inhibit Input may also be used as a means for system shutdown by applying a dc voltage that is within the range of 2.0 V to V_{CC} .

PWM Comparator and Latch

The MC34129 operates as a current mode controller whereby output switch conduction is initiated by the oscillator and terminated when the peak inductor current reaches a threshold level established by the output of the Error Amp or Soft-Start Buffer (Pin 11). Thus the error signal controls the peak inductor current on a cycle-by-cycle basis. The PWM Comparator-Latch configuration used, ensures that only a single pulse appears at the Drive Output during any given oscillator cycle. The inductor current is converted to a voltage by inserting the ground-referenced resistor R_S in series with the source of output switch Q_1 . The Ramp Input adds an offset of 275 mV to this voltage to guarantee that no pulses appear at the Drive Output when Pin 11 is at its lowest state. This occurs at the beginning of the soft-start interval or when the power supply is operating and the load is removed. The

peak inductor current under normal operating conditions is controlled by the voltage at Pin 11 where:

$$I_{pk} = \frac{V_{(Pin\ 11)} - 0.275\ V}{R_S}$$

Abnormal operating conditions occur when the power supply output is overloaded or if output voltage sensing is lost. Under these conditions, the voltage at Pin 11 will be internally clamped to 1.95 V by the output of the Soft-Start Buffer. Therefore the maximum peak switch current is:

$$I_{pk(max)} = \frac{1.95\ V - 0.275}{R_S} = \frac{1.675\ V}{R_S}$$

When designing a high power switching regulator it becomes desirable to reduce the internal clamp voltage in order to keep the power dissipation of R_S to a reasonable level. A simple method which adjusts this voltage in discrete increments is shown in Figure 22. This method is possible because the Ramp Input bias current is always negative (typically -120 μ A). A positive temperature coefficient equal to that of the diode string will be exhibited by $I_{pk(max)}$. An adjustable method that is more precise and temperature stable is shown in Figure 23. Erratic operation due to noise pickup can result if there is an excessive reduction of the clamp voltage. In this situation, high frequency circuit layout techniques are imperative.

A narrow spike on the leading edge of the current waveform can usually be observed and may cause the power supply to exhibit an instability when the output is lightly loaded. This spike is due to the power transformer interwinding capacitance and output rectifier recovery time. The addition of an RC filter on the Ramp Input with a time constant that approximates the spike duration will usually eliminate the instability; refer to Figure 25.

Error Amp and Soft-Start Buffer

A fully-compensated Error Amplifier with access to both inputs and output is provided for maximum design flexibility. The Error Amplifier output is common with that of the Soft-Start Buffer. These outputs are open-collector (sink only) and are ORed together at the inverting input of the PWM Comparator. With this configuration, the amplifier that demands lower peak inductor current dominates control of the loop. Soft-Start is mandatory for stable startup when power is provided through a high source impedance such as the long twisted pair used in telecommunications. It effectively removes the load from the output of the switching power supply upon initial startup. The Soft-Start Buffer is configured as a unity gain follower with the noninverting input connected to Pin 12. An internal 1.0 μ A current source charges the soft-start capacitor ($C_{Soft-Start}$) to an internally clamped level of 1.95 V. The rate of change of peak inductor current, during startup, is programmed by the capacitor value selected. Either the Fault Timer or the Undervoltage Lockout can discharge the soft-start capacitor.

Figure 18. Representative Block Diagram

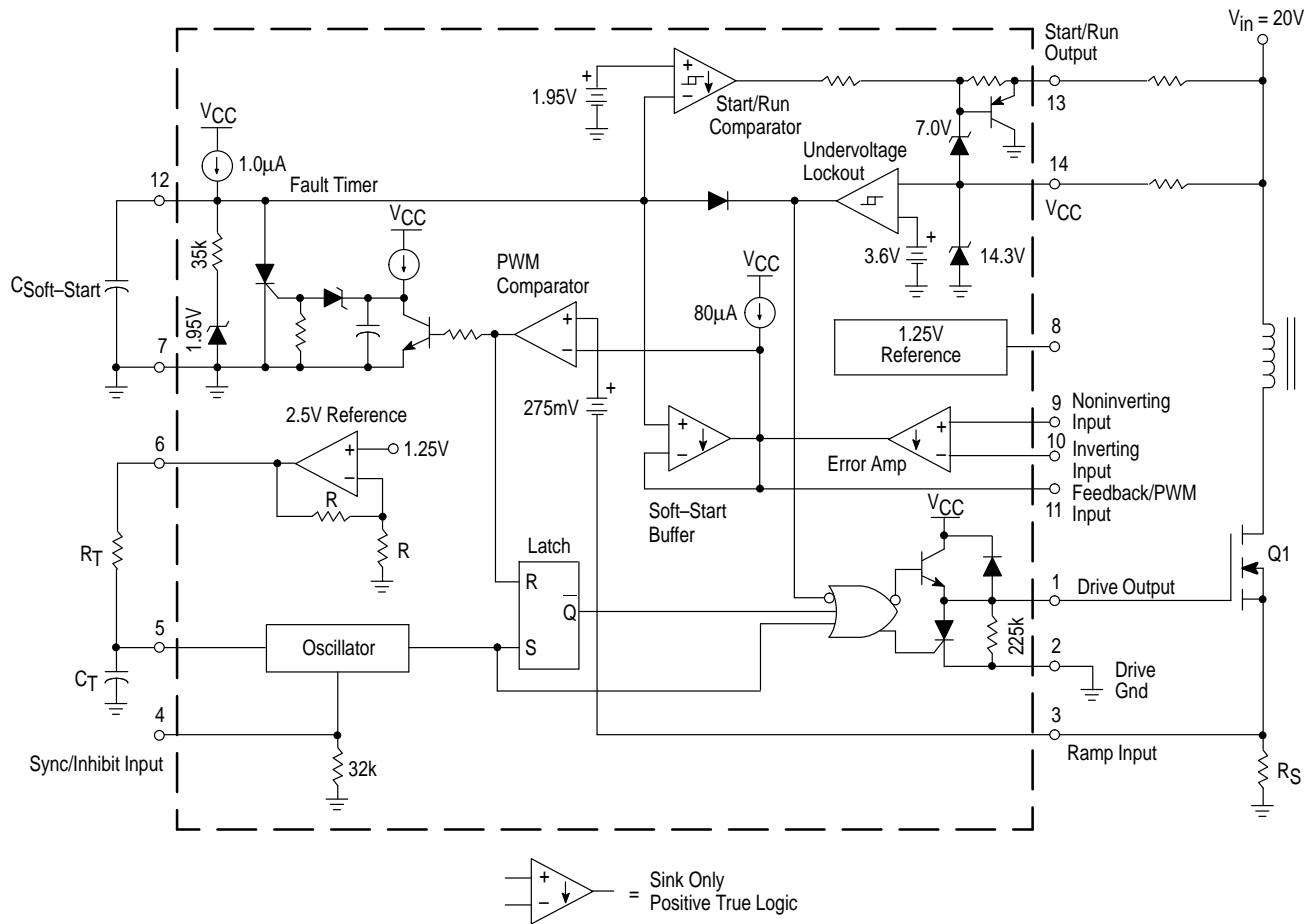
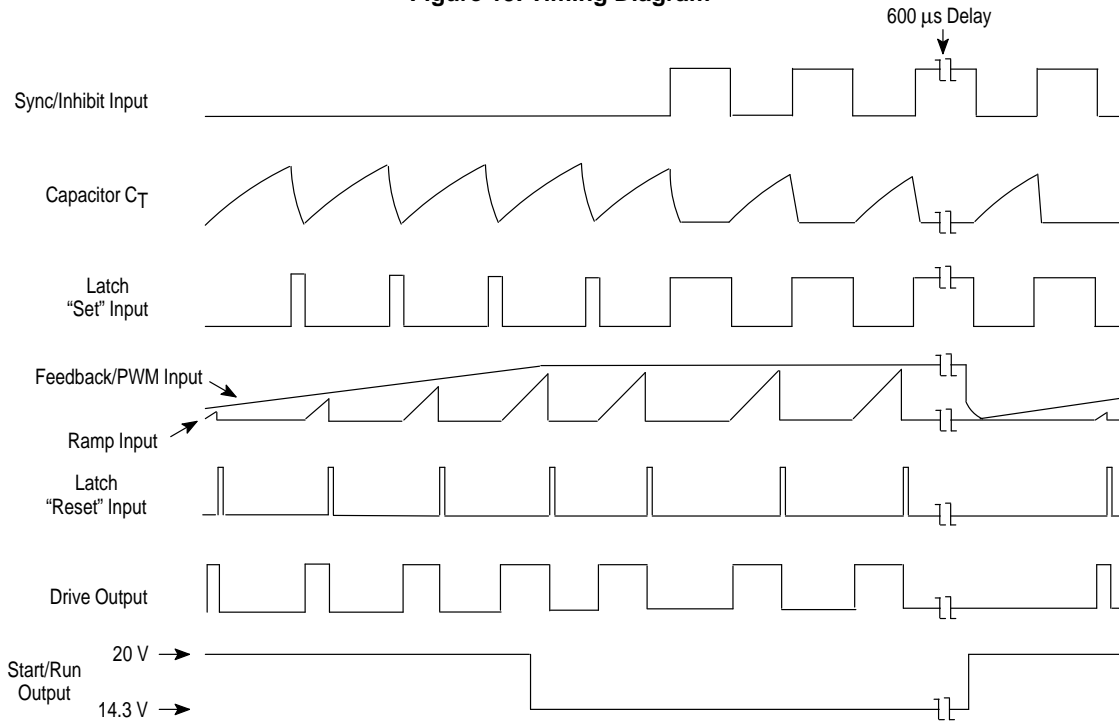

Figure 19. Timing Diagram



Fault Timer

This unique circuit prevents sustained operating in a lockout condition. This can occur with conventional switching control ICs when operating from a power source with a high series impedance. If the power required by the load is greater than that available from the source, the input voltage will collapse, causing the lockout condition. The Fault Timer provides automatic recovery when this condition is detected. Under normal operating conditions, the output of the PWM Comparator will reset the Latch and discharge the internal Fault Timer capacitor on a cycle-by-cycle basis. Under operating conditions where the required power into the load is greater than that available from the source (V_{in}), the Ramp Input voltage (plus offset) will not reach the comparator threshold level (Pin 11), and the output of the PWM Comparator will remain low. If this condition persists for more than 600 μ s, the Fault Timer will activate, discharging $C_{Soft-Start}$ and initiating a soft-start cycle. The power supply will operate in a skip cycle or hiccup mode until either the load power or source impedance is reduced. The minimum fault timeout is 200 μ s, which limits the useful switching frequency to a minimum of 5.0 kHz.

Start/Run Comparator

A bootstrap startup circuit is included to improve system efficiency when operating from a high input voltage. The output of the Start/Run Comparator controls the state of an external transistor. A typical application is shown in Figure 21. While $C_{Soft-Start}$ is charging, startup bias is supplied to V_{CC} (Pin 14) from V_{in} through transistor Q2. When $C_{Soft-Start}$ reaches the 1.95 V clamp level, the Start-Run output switches low ($V_{CC} = 50$ mV), turning off Q2. Operating bias is now derived from the auxiliary bootstrap winding of the transformer, and all drive power is efficiently converted down from V_{in} . The start time must be long enough for the power supply output to reach regulation. This will ensure that there is sufficient bias voltage at the auxiliary bootstrap winding for sustained operation.

$$t_{Start} = \frac{1.95VC_{Soft-Start}}{1.0 \mu A} = 1.95 C_{Soft-Start} \text{ in } \mu F$$

The Start/Run Comparator has 350 mV of hysteresis. The output off-state is clamped to $V_{CC} + 7.6$ V by the internal zener and PNP transistor base-emitter junction.

Drive Output and Drive Ground

The MC34129 contains a single totem-pole output stage that was specifically designed for direct drive of power MOSFETs. It is capable of up to ± 1.0 A peak drive current and has a typical fall time of 30 ns with a 500 pF load. The totem-pole stage consists of an NPN transistor for turn-on drive and a high speed SCR for turn-off. The SCR design requires less average supply current (I_{CC}) when compared to conventional switching control ICs that use an all NPN totem-pole. The SCR accomplishes this during turn-off of the MOSFET, by utilizing the gate charge as regenerative on-bias, whereas the conventional all transistor design requires continuous base current. Conversion efficiency in low power applications is greatly enhanced with this reduction of I_{CC} . The SCR's low-state holding current (I_H) is typically 225 μ A. An internal 225 k Ω pull-down resistor is included to shunt the Drive Output off-state leakage to ground when the Undervoltage Lockout is active. A separate Drive Ground is provided to reduce the effects of switching transient noise imposed on the Ramp Input. This feature becomes particularly useful when the $I_{pk(max)}$ clamp level is reduced. Figure 24 shows the proper implementation of the MC34129 with a current sensing power MOSFET.

Undervoltage Lockout

The Undervoltage Lockout comparator holds the Drive Output and $C_{Soft-Start}$ pins in the low state when V_{CC} is less than 3.6 V. This ensures that the MC34129 is fully functional before the output stage is enabled and a soft-start cycle begins. A built-in hysteresis of 350 mV prevents erratic output behavior as V_{CC} crosses the comparator threshold voltage. A 14.3 V zener is connected as a shunt regulator from V_{CC} to ground. Its purpose is to protect the MOSFET gate from excessive drive voltage during system startup. An external 9.1 V zener is required when driving low threshold MOSFETs. Refer to Figure 21. The minimum operating voltage range of the IC is 4.2 V to 12 V.

References

The 1.25 V bandgap reference is trimmed to $\pm 2.0\%$ tolerance at $T_A = 25^\circ\text{C}$. It is intended to be used in conjunction with the Error Amp. The 2.50 V reference is derived from the 1.25 V reference by an internal op amp with a fixed gain of 2.0. It has an output tolerance of $\pm 5.0\%$ at $T_A = 25^\circ\text{C}$ and its primary purpose is to supply charging current to the oscillator timing capacitor.

For further information, please refer to AN976.

Figure 20. External Duty Cycle Clamp and Multi-Unit Synchronization

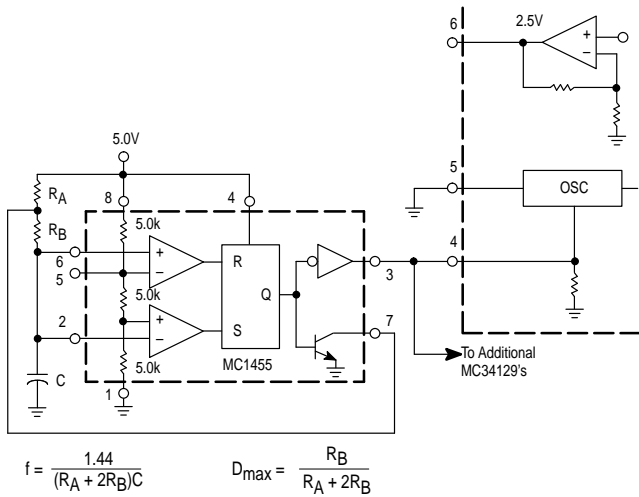

Figure 21. Bootstrap Startup

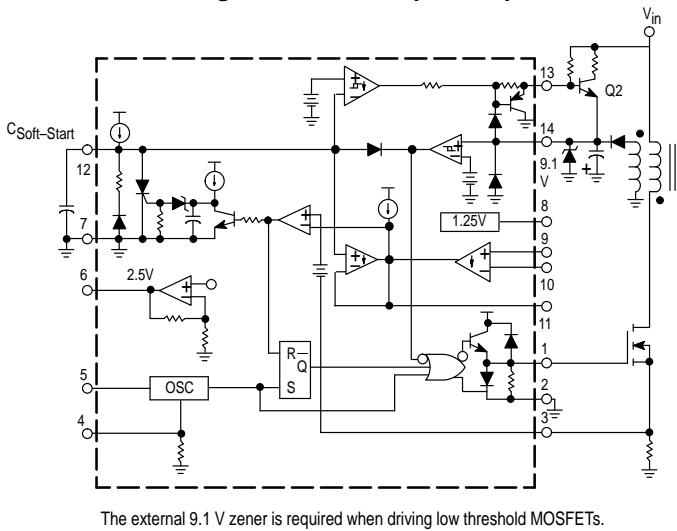

Figure 22. Discrete Step Reduction of Clamp Level

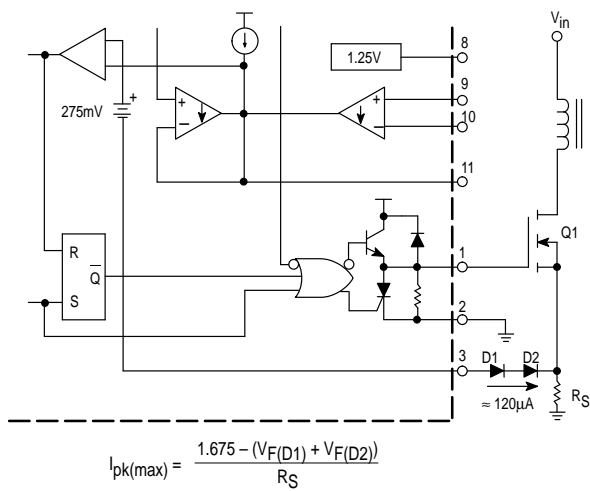

Figure 23. Adjustable Reduction of Clamp Level

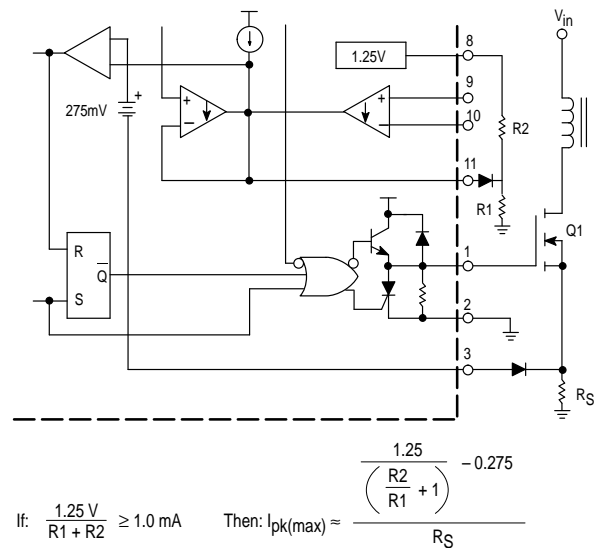
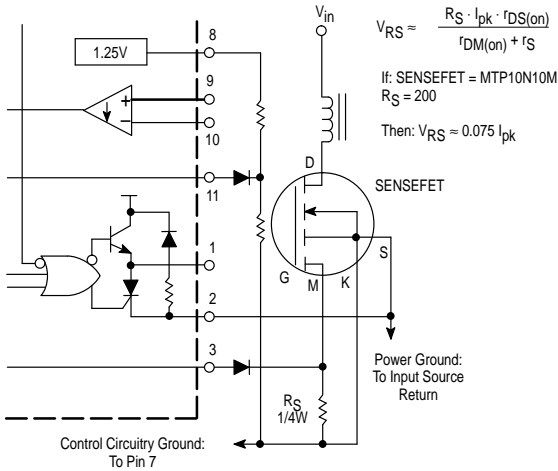
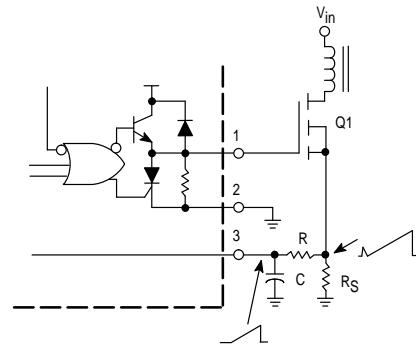

Figure 24. Current Sensing Power MOSFET



Virtually lossless current sensing can be achieved with the implementation of a SENSEFET power switch.

Figure 25. Current Waveform Spike Suppression



The addition of the RC filter will eliminate instability caused by the leading edge spike on the current waveform.

Figure 26. MOSFET Parasitic Oscillations

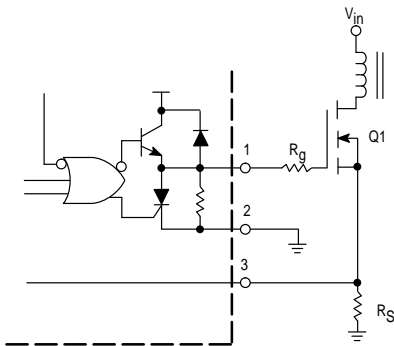

Series gate resistor R_G will damp any high frequency parasitic oscillations caused by the MOSFET input capacitance and any series wiring inductance in the gate-source circuit.

Figure 27. Bipolar Transistor Drive

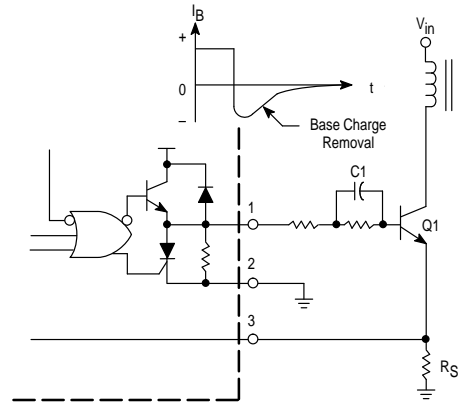

The totem-pole output can furnish negative base current for enhanced transistor turn-off, with the addition of capacitor C1.

Figure 28. Non-Isolated 725 mW Flyback Regulator

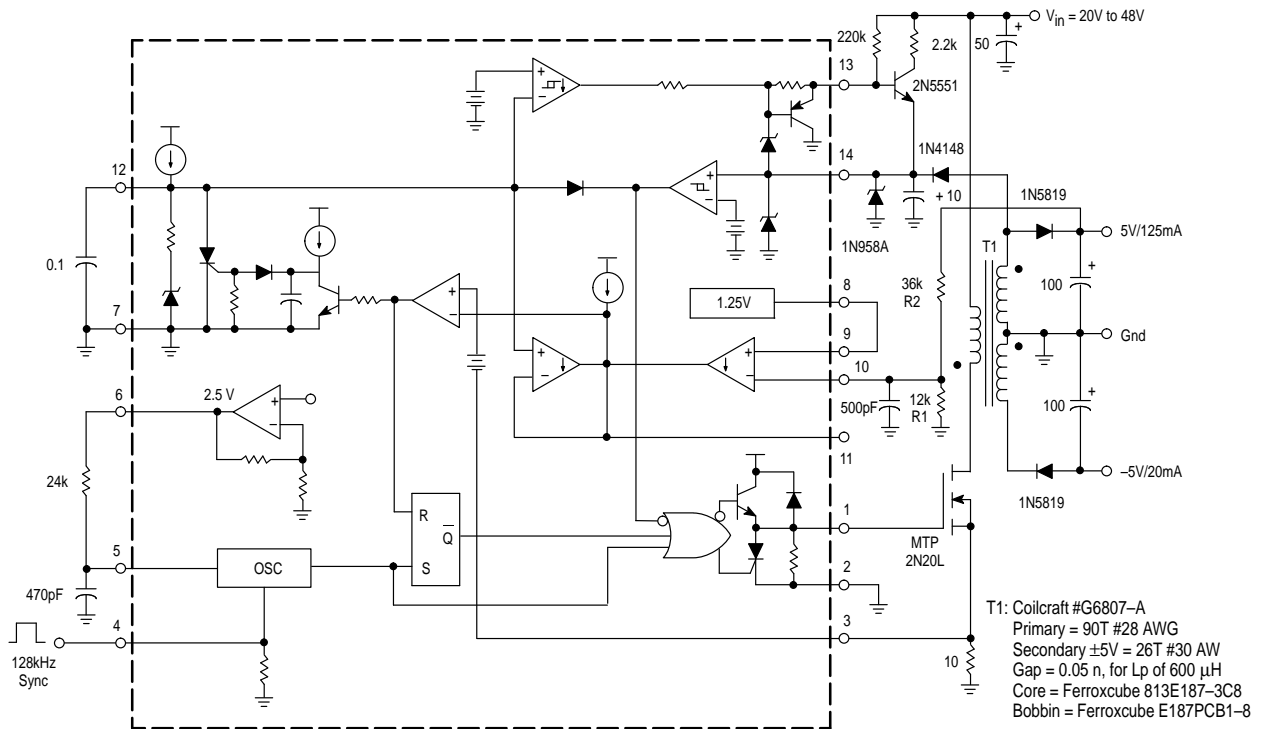

Test	Conditions	Results
Line Regulation 5.0 V	$V_{in} = 20\text{ V to }40\text{ V}$, $I_{out\ 5.0\text{ V}} = 125\text{ mA}$, $I_{out\ -5.0\text{ V}} = 20\text{ mA}$	$\Delta = 1.0\text{ mV}$
Load Regulation 5.0 V	$V_{in} = 30\text{ V}$, $I_{out\ 5.0\text{ V}} = 0\text{ mA to }150\text{ mA}$, $I_{out\ -5.0\text{ V}} = 20\text{ mA}$	$\Delta = 2.0\text{ mV}$
Output Ripple 5.0 V	$V_{in} = 30\text{ V}$, $I_{out\ 5.0\text{ V}} = 125\text{ mA}$, $I_{out\ -5.0\text{ V}} = 20\text{ mA}$	150 mVpp
Efficiency	$V_{in} = 30\text{ V}$, $I_{out\ 5.0\text{ V}} = 125\text{ mA}$, $I_{out\ -5.0\text{ V}} = 20\text{ mA}$	77%

$$V_{out} = 1.25 \left(\frac{R2}{R1} + 1 \right)$$

Figure 29. Isolated 2.0 W Flyback Regulator

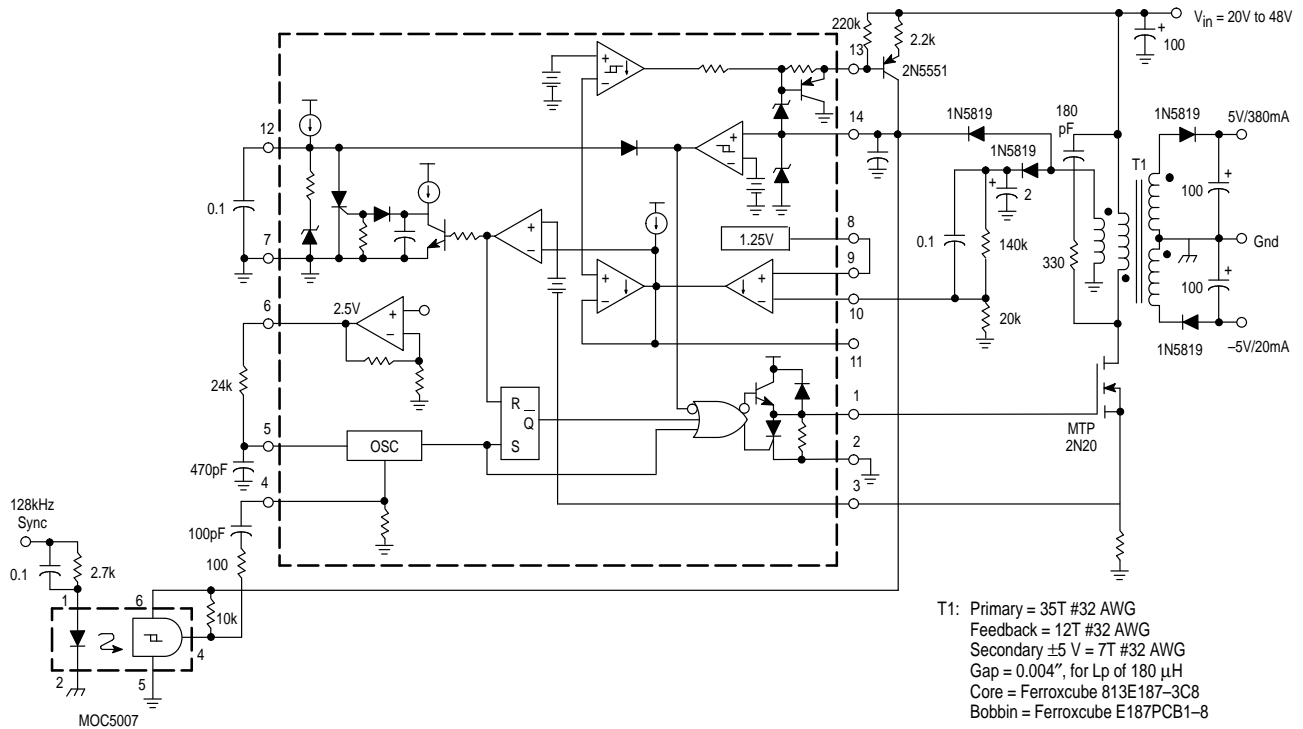

Test	Conditions	Results
Line Regulation 5.0 V	$V_{in} = 20$ V to 40 V, I_{out} 5.0 V = 380 mA, I_{out} -5.0 V = 20 mA	$\Delta = 1.0$ mV
Load Regulation 5.0 V	$V_{in} = 30$ V, I_{out} 5.0 V = 100 mA to 380 mA, I_{out} -5.0 V = 20 mA	$\Delta = 15$ mV
Output Ripple 5.0 V	$V_{in} = 30$ V, I_{out} 5.0 V = 380 mA, I_{out} -5.0 V = 20 mA	150 mVpp
Efficiency	$V_{in} = 30$ V, I_{out} 5.0 V = 380 mA, I_{out} -5.0 V = 20 mA	73%

Figure 30. Isolated 3.0 W Flyback Regulator with Secondary Side Sensing

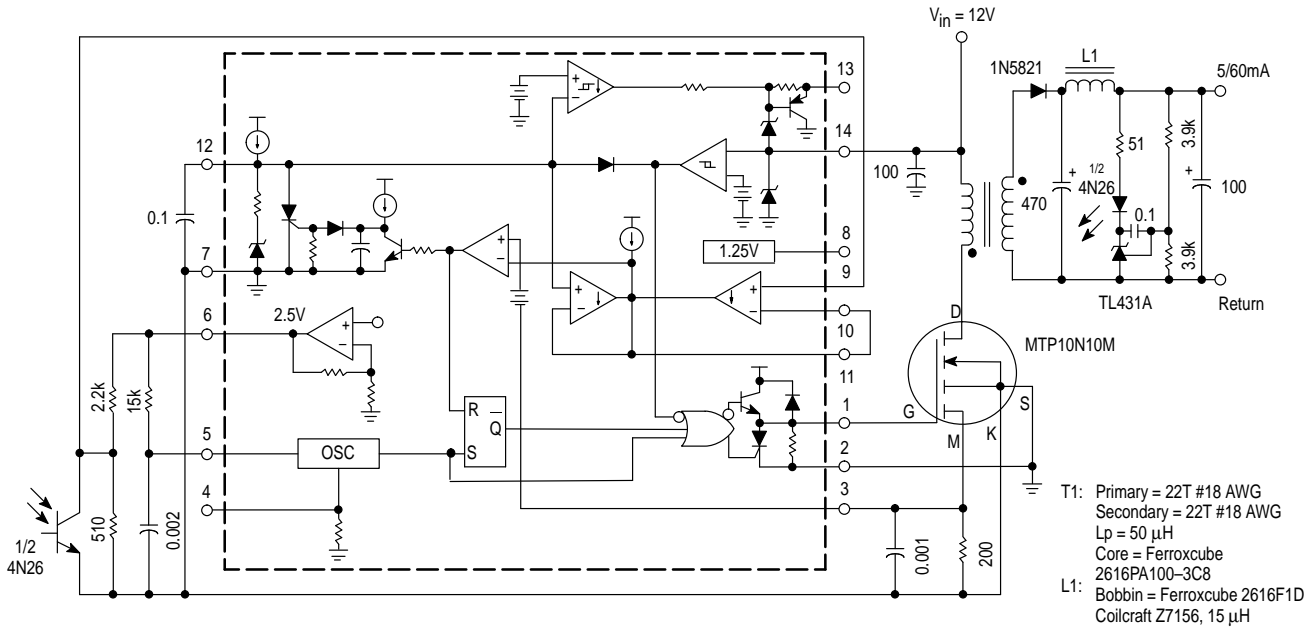

Test	Conditions	Results
Line Regulation	$V_{in} = 8.0 \text{ V to } 12 \text{ V}, I_{out} = 600 \text{ mA}$	$\Delta = 1.0 \text{ mV}$
Load Regulation	$V_{in} = 12 \text{ V}, I_{out} = 100 \text{ mA to } 600 \text{ mA}$	$\Delta = 8.0 \text{ mV}$
Output Ripple	$V_{in} = 12 \text{ V}, I_{out} = 600 \text{ mA}$	20 mVpp
Efficiency	$V_{in} = 12 \text{ V}, I_{out} = 600 \text{ mA}$	81%

An economical method of achieving secondary sensing is to combine the TL431A with a 4N26 optocoupler.

OUTLINE DIMENSIONS

P SUFFIX PLASTIC PACKAGE CASE 646-06 ISSUE L

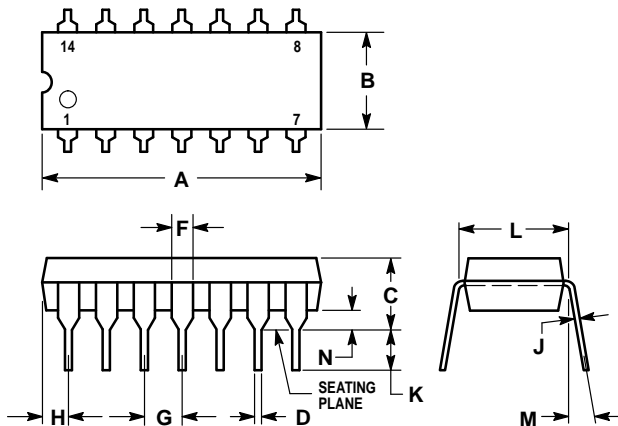

NOTES:

- LEADS WITHIN 0.13 (0.005) RADIUS OF TRUE POSITION AT SEATING PLANE AT MAXIMUM MATERIAL CONDITION.
- DIMENSION L TO CENTER OF LEADS WHEN FORMED PARALLEL.
- DIMENSION B DOES NOT INCLUDE MOLD FLASH.
- ROUNDED CORNERS OPTIONAL.

DIM	INCHES		MILLIMETERS	
	MIN	MAX	MIN	MAX
A	0.715	0.770	18.16	19.56
B	0.240	0.260	6.10	6.60
C	0.145	0.185	3.69	4.69
D	0.015	0.021	0.38	0.53
F	0.040	0.070	1.02	1.78
G	0.100 BSC		2.54 BSC	
H	0.052	0.095	1.32	2.41
J	0.008	0.015	0.20	0.38
K	0.115	0.135	2.92	3.43
L	0.300 BSC		7.62 BSC	
M	0°	10°	0°	10°
N	0.015	0.039	0.39	1.01

D SUFFIX PLASTIC PACKAGE CASE 751A-03 (SO-14) ISSUE F

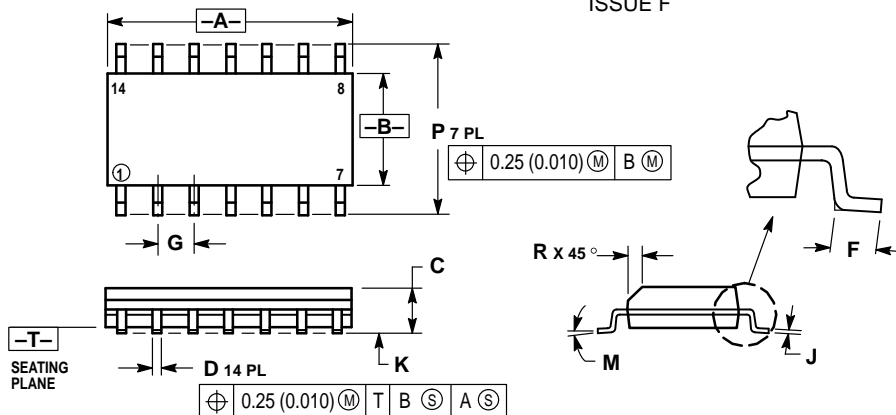

NOTES:

- DIMENSIONING AND TOLERANCING PER ANSI Y14.5M, 1982.
- CONTROLLING DIMENSION: MILLIMETER.
- DIMENSIONS A AND B DO NOT INCLUDE MOLD PROTRUSION.
- MAXIMUM MOLD PROTRUSION 0.15 (0.006) PER SIDE.
- DIMENSION D DOES NOT INCLUDE DAMBAR PROTRUSION. ALLOWABLE DAMBAR PROTRUSION SHALL BE 0.127 (0.005) TOTAL IN EXCESS OF THE D DIMENSION AT MAXIMUM MATERIAL CONDITION.

DIM	MILLIMETERS		INCHES	
	MIN	MAX	MIN	MAX
A	8.55	8.75	0.337	0.344
B	3.80	4.00	0.150	0.157
C	1.35	1.75	0.054	0.068
D	0.35	0.49	0.014	0.019
F	0.40	1.25	0.016	0.049
G	1.27 BSC		0.050 BSC	
J	0.19	0.25	0.008	0.009
K	0.10	0.25	0.004	0.009
M	0°	7°	0°	7°
P	5.80	6.20	0.228	0.244
R	0.25	0.50	0.010	0.019

Motorola reserves the right to make changes without further notice to any products herein. Motorola makes no warranty, representation or guarantee regarding the suitability of its products for any particular purpose, nor does Motorola assume any liability arising out of the application or use of any product or circuit, and specifically disclaims any and all liability, including without limitation consequential or incidental damages. "Typical" parameters which may be provided in Motorola data sheets and/or specifications can and do vary in different applications and actual performance may vary over time. All operating parameters, including "Typicals" must be validated for each customer application by customer's technical experts. Motorola does not convey any license under its patent rights nor the rights of others. Motorola products are not designed, intended, or authorized for use as components in systems intended for surgical implant into the body, or other applications intended to support or sustain life, or for any other application in which the failure of the Motorola product could create a situation where personal injury or death may occur. Should Buyer purchase or use Motorola products for any such unintended or unauthorized application, Buyer shall indemnify and hold Motorola and its officers, employees, subsidiaries, affiliates, and distributors harmless against all claims, costs, damages, and expenses, and reasonable attorney fees arising out of, directly or indirectly, any claim of personal injury or death associated with such unintended or unauthorized use, even if such claim alleges that Motorola was negligent regarding the design or manufacture of the part. Motorola and  registered trademarks of Motorola, Inc. Motorola, Inc. is an Equal Opportunity/Affirmative Action Employer.

How to reach us:

USA/EUROPE/Locations Not Listed: Motorola Literature Distribution;
P.O. Box 20912; Phoenix, Arizona 85036. 1-800-441-2447 or 602-303-5454

JAPAN: Nippon Motorola Ltd.; Tatsumi-SPD-JLDC, 6F Seibu-Butsuryu-Center,
3-14-2 Tatsumi Koto-Ku, Tokyo 135, Japan. 03-81-3521-8315

ASIA/PACIFIC: Motorola Semiconductors H.K. Ltd.; 8B Tai Ping Industrial Park,
1 Ting Kok Road, Tai Po, N.T., Hong Kong. 852-26629298



MOTOROLA

For More Information On This Product,
Go to: www.freescale.com

MC34129/D

